



匯統國際股份有限公司

Huey Tung International Co., Ltd.

# 產品規格書

# Specification

[ Model : HT-1004 / 2007.09.25 version ]



**Cara Audio Corporation**

No.69, Lane 762, Dingzhong Road, Sanmin District, Kaohsiung City, Taiwan, ROC.

Tel: 886-7-310 5786 / Fax: 886-7-310 0783

E-mail: [carawang@hueytung.com.tw](mailto:carawang@hueytung.com.tw) / <http://www.hueytung.com.tw>

# 揚聲器製品規格書

## SPEAKER SPECIFICATION

型號 Model Number: HT-1004

項目 Items		規格 Specification		
1	公称阻抗 Nominal Impedance	4Ω±15%		
2	最低共振周波数 Lowest Resonance Frequency	/ Hz±20%Hz Without a baffle		
3	实效周波数带域 Effective Frequency Range	2KHz~20KHz -10dB		
4	出力音压 Output Sound Pressure Level	85dB±3dB 1W/1M at (3K,4K,5K,6K)Hz AVE.		
5	入力 Input	定格入力 Rated input 15 W	最大入力 Maximum input 30W	
6	磁束密度 Flux Density	-----±10% GAUSS		
7	异常音试验电压 Buzz & Rattle Test	Must be normal at sine wave 2.0 V		
8	动作试验电压 Operation Test	Must be normal at program source		
9	极性 Polarity	左爲正極		
10	磁石尺寸/重量 Magnet Dimension/Weigh	Magnet: 32 * 18* 6 Sub Magnet: 32 * 18* 6 m/m	16.48g ( 0.58 OZ) 16.48g ( 0.58 OZ)	
11	连续负荷试验 Life Test	7.8V(4Ω/15W) EIA-RS426B 8hours WITH 3.3UF/50V CAPACITOR	After the Test, Speaker should be meet the Outside and item 7,8	
12	耐热试验 Heat Resistance	70°C±2°C 20%-50%RH 24Hours and then room temperature 1 hours		
13	耐湿试验 Humidity Resistance	40°C±2°C 90%-95%RH 24Hours and then room temperature 1 hours		
14	耐寒试验 Cold Resistance	-25°C±2°C 24Hours and then room temperature 1 hours		
15	落下试验 Drop Test	1M 75°±2°		
16	绝缘耐压试验 Insulation Resistance	Or more 1MΩ 以上		
17	周波数特性 Frequency Response Curve	参照附图 On Other Drawing		
18	失真率 Distortion	/		
19	各部 材质	Cone Paper	PAPER + SILK EDGE	
		Voice Coil	Φ 13.28mm PAPER	
		Cap	Φ 20 mm	
20	总重量 Total Weight	98g( 3.46 OZ)		
	Size: 40mm 試作發行: 2007. 09. 26	Approve:  Arthur	Check:  Tang	Design:  WANG

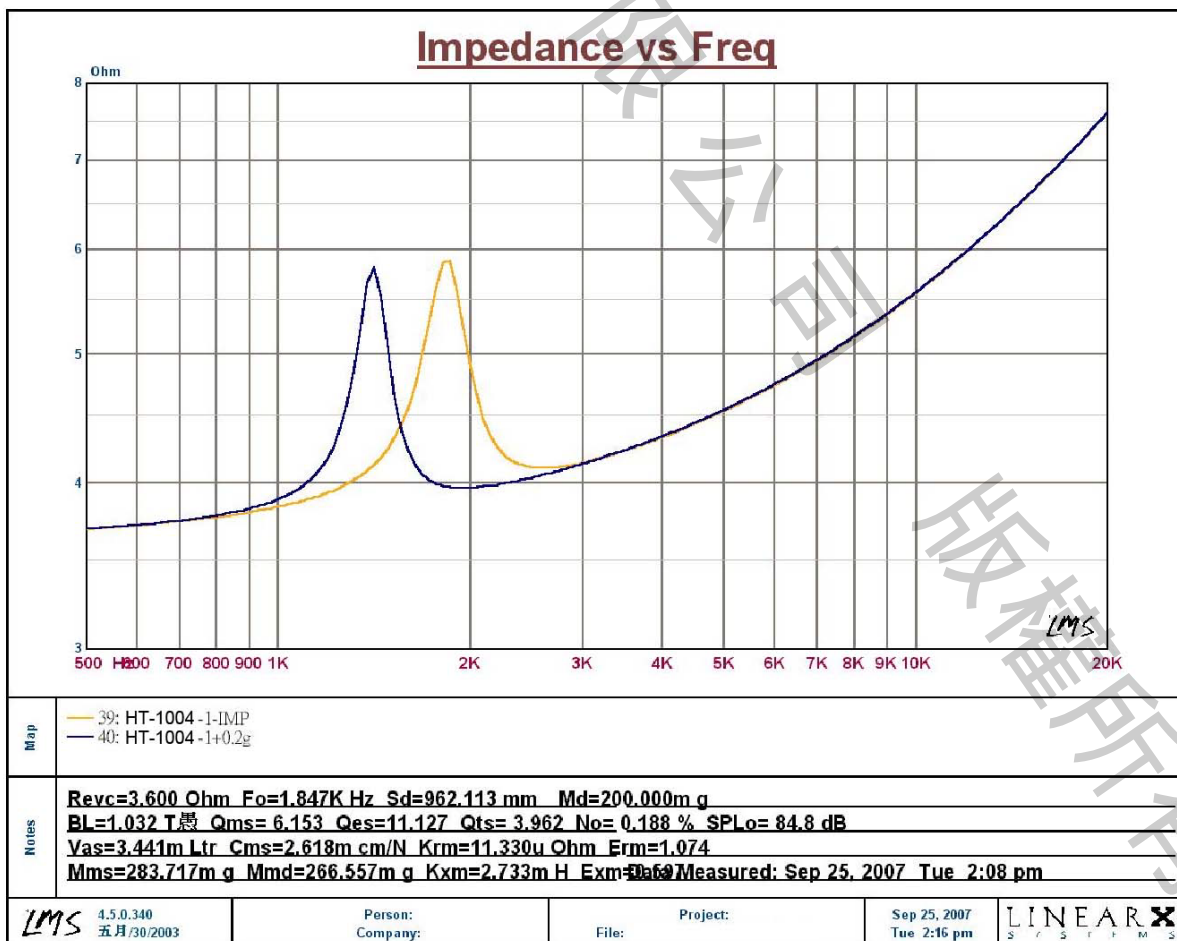
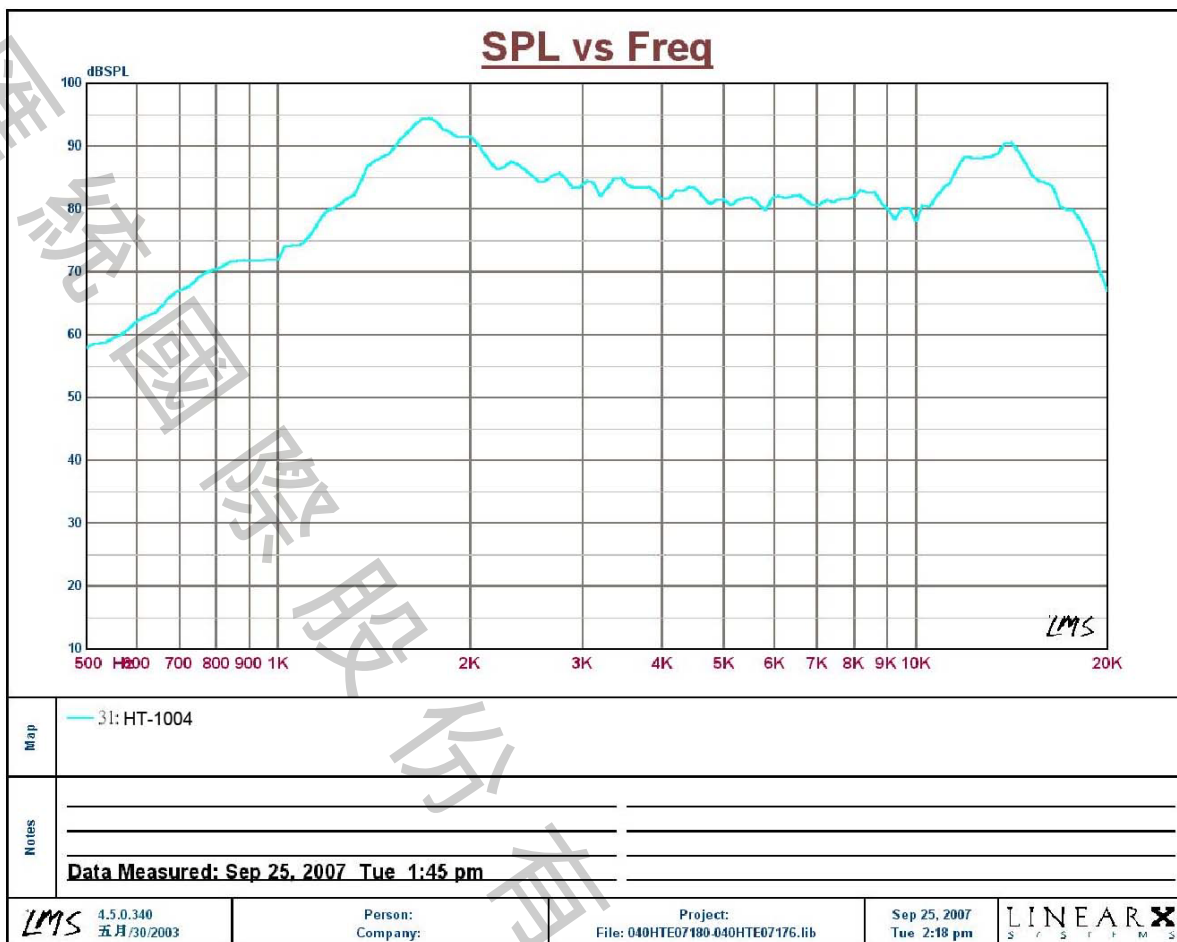

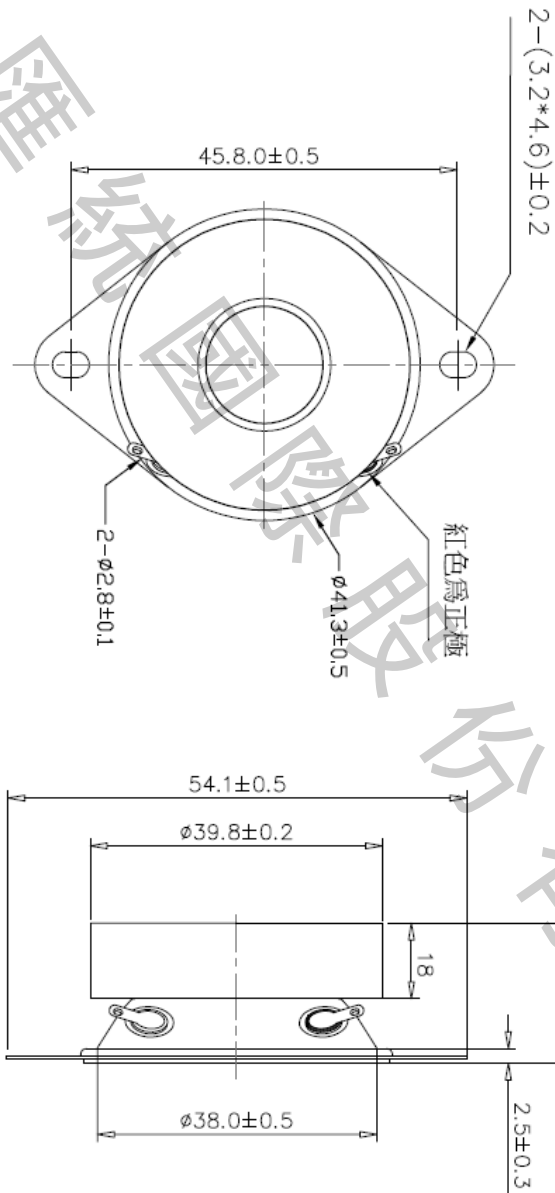

Toerance:  $\pm 0.5$   
Unit:mm